

Quality Policy Statement

Lexus SoftMac™ is ISO 9001:2000 Company

*We, at “Lexus SoftMac”,
make our Quality so special, So Valuable to our Customers,
so Important to their Success,
that our Products become their only Real Value Choice.*

CEO

Date: 01.02.05

CONTENTS

Welcome.....	2
Specification, Standard Accessories and Extra Accessories.....	3
Application and Highlight.....	4
Introduction.....	5
Installation.....	6
Operating Controls.....	7
Operating Instruction.....	8
Comparison.....	10
Explanation of Silhouette Screen.....	12
Troubleshooting.....	13

Information in this document, including URL and other Internet Web Site reference is subject to change without notice. Unless otherwise noted, the example companies, organization, products, domain names, e-mail addresses, logos, people, places, and events depicted herein are fictitious and no association with any real company, organization, products, domain name, e-mail address, logo, person, place or event is intended or should be inferred. Complying with all applicable copyright laws is the responsibility of the user. Without limiting the rights under copyright, no part of this document may be reproduced, stored in or introduced into a retrieval system, or transmitted in any form or by any means (electronic, mechanical, photocopying, recording, or otherwise), or for any purpose, without the express written permission of Lexus SoftMac

Lexus may have patents, patent applications, trademarks, copyrights, or other intellectual property rights covering subject matter in this document. Except as expressly provided in any written license agreement from Lexus, the furnishing of this document does not give you any license to these patents, trademarks, copyrights, or other intellectual property.

Lexus SoftMac (100% EOU). All rights reserved. Lexus products are licensed to the users by Lexus
Lexus and its Logo are either registered trademarks or trademarks of Lexus SoftMac , INDIA. And/or other countries.

The names of actual companies and products mentioned herein may be the trademarks of their respective owners.

WELCOME

Get ready for a whole new experience.

Lexus 8mm Econobruter has a completely fresh, new look and it's easier than ever to use.

This booklet explains how to get your Lexus 8mm Econobruter set up and where to turn for help, so you can enjoy the most intuitive Bruting System yet for Real gem quality Diamonds.

Let's get started!

SPECIFICATIONS

✚	Weight	: 40 kg.
✚	Dimension	: 660 x 550 x 280 mm
✚	Supply	: 220 VAC , 50 HZ , 1 Phase
✚	Load	: 400 VA
✚	Lighting	: 12 V 10W

STANDARD ACCESSORIES

✚	LN key (T-Handle) - 3 mm.	- 1 No.
✚	Die Pot	- 20 Nos.
✚	Hammer	- 1 No.
✚	Spindle Spanner set	- 1 No.

EXTRA ACCESSORIES

✚	Glue Bottle - 6 gms.
✚	Oven Plate.
✚	Oven.
✚	Soldering Iron.
✚	LN Key Set.
✚	Fancy Die pots.
✚	Servo Stabilizer
✚	Gluing Station.
✚	Lexus Dia-Centering.
✚	Lexus Fancy Centering Machine.

APPLICATION

To barrel brute a pre-tabled diamond to form a cylindrical girdle for a Round Brilliant.

HIGHLIGHTS

- ✦ Suitable for both, Saw-able & Make-able.
- ✦ Silhouette viewing system with ergonomically designed graph to have better judgment of bruiting.
- ✦ Two Stones can be simultaneously bruited.
- ✦ Beardless surface finish, requiring no further girdle finishing.
- ✦ Better control and safe operation adds to recovery.
- ✦ Single operator can run up to 10 Machines.
- ✦ Handles all sizes between 5 cents to 15 carats.
- ✦ Correct speed for every stone thru variable speed control.
- ✦ Can be used for generating fancy shapes as well.
- ✦ Can be used in conjunction with Lexus Dia-Centering and Lexus Fancy Centering, for fairly accurate control and doing away with poorly skilled operator.
- ✦ Fastest return on the investment

INTRODUCTION

These machines are pre-dominantly used as pre-bruters for expensive goods to cut down production cost, beardless surface finish and control on accidental damages, prior to high cost Auto Bruting Process. For smaller and inexpensive goods, these machines act as final bruting machine, controlling recovery as well as curtailing production cost.

The Silhouette viewing system with ergonomically designed graph, gives a better judgment to the operator to control the bruting process. The Variable RPM on the spindle has suitable speed for all kind and sizes of stones, to handle vulnerable pieces with ease.

Specially designed O-type Preloading system for spindle bearings, with negative clearance, adds to the spindle rigidity, controlling the deflection under higher cutting forces, generating better roundness.

The Rugged construction with experience of more than 11 years, makes the machine fail-safe and with longer service life, resulting in high MTBF.

INSTALLATION

Unpack the machine, while unscrewing the two side clamps, which holds down the machine on base pallet

1. Remove all movement restricting packing.
2. Place the machine on a sturdy bench (around 750 mm high).
3. Connect the 3 pin plug in a 230V – 1 Phase – 50 Hz power, wall plug socket.

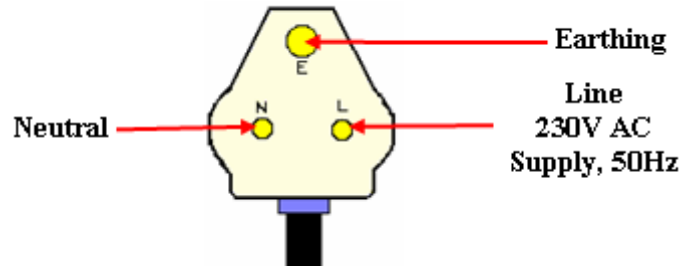

OPERATING CONTROLS

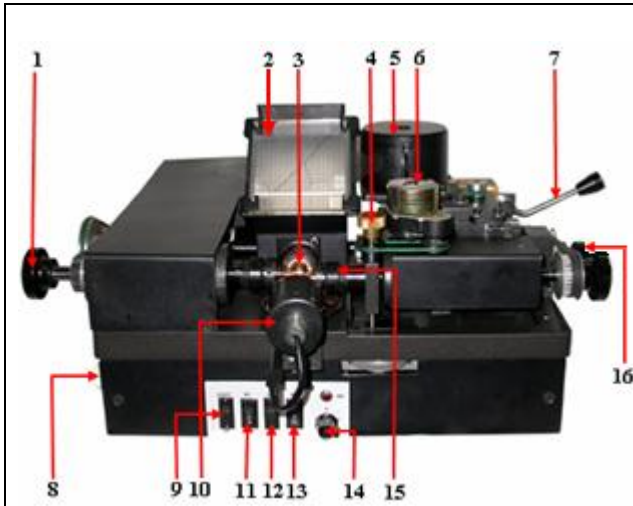

1. Main Spindle
2. Silhouette Screen
3. Lens
4. Timer Screw
5. Sliding Motor(M2)
6. Pressure Motor(M3)
7. Stroke Setting Lever
8. Main Motor Speed Controller
9. Back Light Switch

10. Back Light Housing
11. M1 Switch
12. M2 Switch
13. M3 Switch
14. Timer Pot
15. Fighter Spindle
16. Stroke Position Setting Knob

OPERATING INSTRUCTION

1. Keep the machine on a level surface with rigid structure.
2. Connect the power supply to the machine.
3. Glue the tentative table surface of the stone on the die pot. Take the glue as little as possible, just to remain between the table surface and the die pot-gluing surface. **EXTRA GLUE DOES NOT ADD TO THE BONDING STRENGTH.**
*Gluing Station can be used to assist proper gluing process. Cure the glue by putting the die pot along with oven plate in oven for around 12 to 15 minutes at a temperature of 180 degree centigrade. **LEVELLING OF OVEN IS VERY IMPORTANT TO AVOID SHIFTING OF THE STONE DURING GLUE CURING.** (*If you are using 13mm Econobruiter with Centering machine then gluing station is not necessary).
4. Keeping the machine Main Switch in OFF position and fix the fighter stone in the fighter spindle. Use the grub screw to tighten the die pot.
5. Switch ON the light, and set the fighter using the projection details on the silhouette screen. Use the hammer to do so.
6. Take the fighter spindle down enough to avoid accident with the main stone.
7. Fix the main stone in fix spindle, again while tightening the grub screw, and keeping the table surface in line with table line on the main graph.
8. Use the Main Graph to control the desired crown height, sliding graph to control the desired pavilion height and combination of both to control the total height of the finished stone.

9. Manually rotate the spindle to make sure that both the stone do not touch each other accidentally.
10. Bring both the stones close together using timer screw, while rotating the spindle manually.
11. Switch on the Main Switch and start spindle rotation by putting the M1 in forward rotation position. Cautiously bring the stones close together. Start M2 motor, and adjust the stroke size and position by respective lever / knob.
12. Start the pressure by putting M3 motor switch in UP position. Set the timer knob for appropriate rate of cutting.
13. Keep a watch on the graph to terminate the bruiting process. Occasionally, the machine can be stopped (by switching OFF the main switch) to have a look at the stone more closely.
14. If during the process, the bruiting surface starts signing too much, and you want to brute the piece further, reverse the spindle direction of rotation, to remove the signing surface. Also the speed of rotation can be lowered to do so.
15. On approaching the required size, slow down the feed rate gradually (to zero) to get beardless surface finish with higher control on roundness. Occasionally Reverse-Forward the main spindle to remove larger pressure built up. This will greatly affect the roundness

COMPARISON

The machine from LEXUS is differ from other Maxicut models in following respect:

1. As the Maxicut designed in South Africa were supposed to handle goods in De Beers Controlled manufacturing factories, where they were handling more or less fix size and type of rough stone, they were designed with fix spindle RPM. Whereas, we wanted to handle all kind of rough with large variation in size, and so designed this machine with variable RPM, whereby we can have perfectly suitable speed for each size of stone.
2. The machine from Lexus has diamond-truing system on both the spindle, to take diamonds on both the spindle during first bruiting. Whereas, the other Maxicut model was designed to use rejection for bruiting. And so the fighter stone cannot be trued.
3. To use a diamond as fighter on Maxicut models, you need a setting station, where the stone is glued in centre of the die pot (to account for non-truing system on Maxicut fighter spindle.) Where as on machine from Lexus, this setting or gluing station is not necessary. (Normally, during glue curing in oven, the stone shifts a little, which cannot be accounted in Maxicut fighter spindle).
4. The die pot mounting system in Lexus gives consistent tightening over a full life period of the machine. Whereas in basic Maxicut models the clamping system develops clearance with time and causes poor roundness then after.
5. The machine from Lexus is designed basically to handle larger size goods. So the spindle bearing size and sliding bearing size are much larger compared to basic Maxicut models, to give high rigidity and better roundness.
6. The machine feed pulse in Lexus is as small as 1 micron to give smooth, beardless girdle. Whereas in basic maxicuts the pulse is as large as 5 to 10 micron, causing cheeping at table and gets opening.

7. The machine from Lexus is almost twice the weight of basic maxicuts, which reflect its rigidity and better performance.
8. The number of machines installed by Lexus outnumbers the installation by all other manufacturer put together, by more than 50 %.
9. The machine from Lexus is upgradeable to Auto Bruter.
10. The machine from Lexus can be used for Fancy Bruting also.
11. The machine from Lexus has a special truing system, which is particularly very advantageous in bruting crossed culet flat stones.
12. The machine maintenance is very simple and low cost. Even the lighting used for Silhouette system uses an easily available bulb from automobile (costing around US \$ 0.10). Whereas the Maxicut machine uses a special bulb costing around US \$ 6.50 to US \$ 11.00).
13. All the three movements are independently controlled motor movements. This is very useful in handling vulnerable stones and to achieve better roundness and surface finish at the girdle.

More over this machine can be used in conjunction with Lexus Dia-Centering (with 13mm Presetting die pots), which works more or less like OGI and BETTONVILLE automatic bruting machine except for one exception of auto stopping (which can be controlled by any average operator). In this case the Lexus Econobruter (13 mm) with price tag of US \$ 570.00, is incomparable to any other make AutoBruters. Magnification on Lexus Econobruter Silhouette is around 10X. Whereas magnification of the other AutoBruters is around 6X. This Econobruter Silhouette can be upgraded to real image TV projection with an addition of around US \$ 550.00 per machine (which can directly compare with the other two AutoBruters).



EXPLANATION OF SILHOUETTE SCREEN

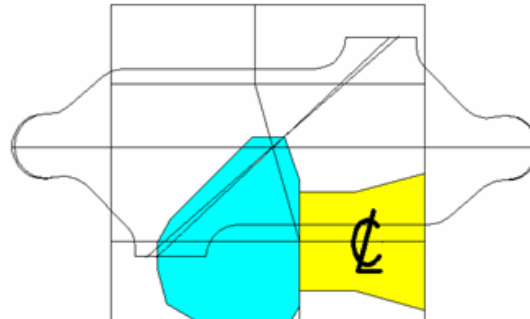
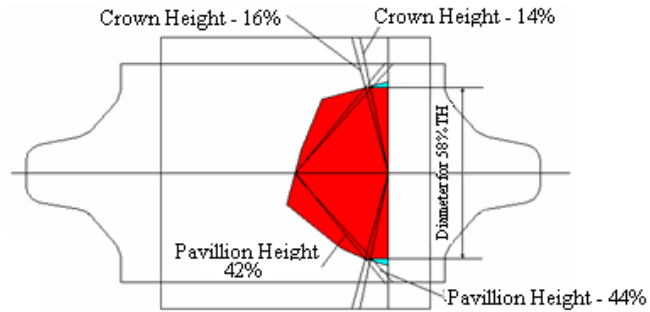

TROUBLESHOOTING

Sr. No.	Problems	Reasons	Solutions
1	Pressure is not coming.	<ul style="list-style-type: none"> a. Timer switch is not ON. b. Timer screw is tight / jam. c. Timer switch is faulty. d. Timer motor's capacitor faulty. e. Threads of timer screw and nut are worn out. f. Belt is slipping. 	<ul style="list-style-type: none"> a. Switch ON the timer switch. b. Clean the timer screw using clean cloth. c. Change the timer switch. d. Change the capacitor. e. Change screw-nut set. f. Clean the belt using clean cloth or change the belt.
2	Machine is running slowly.	<ul style="list-style-type: none"> a. Rider knob is at slow position. b. Main motor belt is slipping. c. PTFE bush of the counter shaft may be dry. 	<ul style="list-style-type: none"> a. Turn the rider knob. b. Clean the motor belt using clean cloth or change the belt c. Put a few oil drops.
3	The main motor (M1) speed is not controlled by the rider.	<ul style="list-style-type: none"> a. Rider is faulty. 	<ul style="list-style-type: none"> a. Change the rider.
4	Noise from the fighter spindle.	<ul style="list-style-type: none"> a. Fighter spindle is in too much down position. b. Counter shaft PTFE bush may have worn out. c. Timing belt may have worn out. d. Timing pulley has worn out. 	<ul style="list-style-type: none"> a. Take fighter spindle in up position. b. Change countershaft bush. c. Change timing belt. d. Change timing pulley

5	Sliding movement problem.	<ul style="list-style-type: none"> a. Sliding eccentric shaft may be tight between Nylon bush. b. There is an access clearance between eccentric shaft and the Nylons bush. c. Belt slipping d. Sliding motor (M2) is not running properly. 	<ul style="list-style-type: none"> a. Rotate the Nylon bush and create a little clearance. b. Rotate the Nylon bush and reduce the clearance. c. Clean the belt using neat cloth or change the belt. d. Change the capacitor of R-C circuit or change the M2-Motor.
6	Noise problem when machine is running at high speed.	<ul style="list-style-type: none"> a. Pedestal bearings of countershaft are dry. 	<ul style="list-style-type: none"> a. Put a few oil drops in the pedestal.
7	Electric shock from machine.	<ul style="list-style-type: none"> a. Earthing is not proper. 	<ul style="list-style-type: none"> a. Make proper earthing in your factory wiring.
8	Noise problem in machine.	<ul style="list-style-type: none"> a. Main motor (M1) bearing may be faulty. (Can be confirmed by removing M1 motor belt). b. Counter shaft may be dry. c. Main (fixed) spindle bearing dry or worn out. d. Fighter spindle bearing dry or worn out. 	<ul style="list-style-type: none"> a. Change M1 motor bearing. b. Put oil drops in counter shaft pedestal. c. If dry then grease it and if worn out, change it. d. If dry then grease it and if worn out, change it.

9	Roundness of Diamond after zoeting is not good enough. (I.e. poorer than 99%	<ul style="list-style-type: none"> a. Roundness is not achieved on whole diamond. (Uniform 'zoeting' is not found on the total girdle periphery.) b. Water is applied during zoeting cycle. c. Powder is removed from diamond before full roundness is achieved. d. Sliding-bearing pad has worn out. e. If uniform zoet is found on the total diamond periphery and roundness is not satisfactory, spindle bearings are not properly preloaded. 	<ul style="list-style-type: none"> a. Do not correct / tap the diamond just before zoeting cycle. b. Do not apply water. c. Do not remove powder during zoeting cycle. d. Change the sliding pad and bush. e. Check spindle Bearing and preload by tightening the locking nut.
10	Fuse blown again and again.	<ul style="list-style-type: none"> a. Wiring may be shorted. b. Main motor (M1) may be faulty. c. Transformer may be shorted. 	<ul style="list-style-type: none"> a. Check wiring. b. Check the main motor; if motor is shorted then change the motor. c. Change the transformer
11	Timer is moving fast.	<ul style="list-style-type: none"> a. In timer PCB circuit, the resistor value is 2kΩ. 	<ul style="list-style-type: none"> a. Replace 2kΩ resistor by 750Ω resistor.
12	Vibration in machine.	<ul style="list-style-type: none"> a. Table is weak. 	<ul style="list-style-type: none"> a. Fix the table securely.