

Quality Policy Statement

Lexus SoftMac™ is ISO 9001:2000 Company

*We, at “Lexus SoftMac”,
make our Quality so special, So Valuable to our Customers,
so Important to their Success,
that our Products become their only Real Value Choice.*

CEO

Date: 01.02.05

CONTENTS

- Welcome 2
- Specification, Standard Accessories and Extra Accessories 3
- Application and About the Machine 4
- Installation 5
- Operating Controls 6
- Operating Instruction 7
- Chart for Calculating Brutening Radius 9
- Distance from Centre Line for Oval 9
- Distance from Centre Line for Marquise 10
- Distance from Centre Line for Pear 11
- Troubleshooting of Fancy Brutening Machine 12

Information in this document, including URL and other Internet Web Site reference is subject to change without notice. Unless otherwise noted, the example companies, organization, products, domain names, e-mail addresses, logos, people, places, and events depicted herein are fictitious and no association with any real company, organization, products, domain name, e-mail address, logo, person, place or event is intended or should be inferred. Complying with all applicable copyright laws is the responsibility of the user. Without limiting the rights under copyright, no part of this document may be reproduced, stored in or introduced into a retrieval system, or transmitted in any form or by any means (electronic, mechanical, photocopying, recording, or otherwise), or for any purpose, without the express written permission of Lexus SoftMac.

Lexus may have patents, patent applications, trademarks, copyrights, or other intellectual property rights covering subject matter in this document. Except as expressly provided in any written license agreement from Lexus, the furnishing of this document does not give you any license to these patents, trademarks, copyrights, or other intellectual property.

Lexus SoftMac (100% EOU). All rights reserved. Lexus products are licensed to the users by Lexus.

Lexus and its Logo are either registered trademarks or trademarks of Lexus SoftMac, INDIA. And/or other countries.

The names of actual companies and products mentioned herein may be the trademarks of their respective owners.

WELCOME

Get ready for a whole new experience.

Lexus Fancy Bruting Machine (Full Rotation) has a completely fresh, new look and it's easier than ever to use.

This booklet explains how to get your Lexus Fancy Bruting Machine (Full Rotation) set up and where to turn for help, so you can enjoy the most intuitive Bruting System yet for Real gem quality Diamonds.

Let's get started!

SPECIFICATIONS

- + Weight : 38 kg
- + Dimension : 620 x 510 x 310 mm
- + Supply : 220 VAC , 50 HZ , 1 Phase
- + Load : 400 VA
- + Lighting : 12 VDC,10 Watts

STANDARD ACCESSORIES

- + 8mm Die Pots for Fancy : 10 Nos.
- + 8mm Die Pots for Fighter : 10 Nos.
- + 3 mm LN Key : 1 No.
- + 5 mm LN Key : 1 No.
- + C-Spanner for Spindle : 1 No.
- + ¼" Stud : 1 No.
- + Hammer : 1 No.

EXTRA ACCESSORIES

- + Fancy Chuck
- + Oven

APPLICATION

To barrel brute a pre-tabled Fancy shape diamond (Marquise – Point of Pear and belly of Oval).

INSTALLATION

Unpack the machine, while unscrewing the two side clamps, which holds down the machine on base pallet

1. Remove all movement restricting packing.

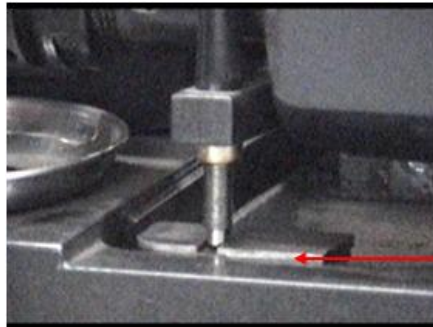

Make sure, this floating pad is in position after unpacking the machine (and not misplaced in transportation)

2. Place the machine on a sturdy bench (around 750 mm high).
3. Connect the 3 pin plug in a 230V – 1 Phase – 50 Hz power, wall plug socket.

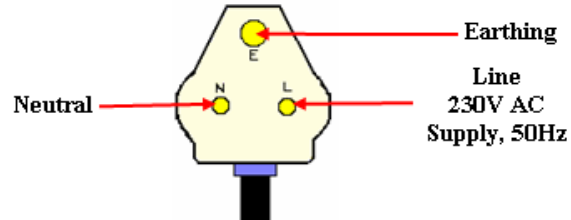

4. Find out magnification of graph as per as following instruction.
 - ⊕ Take 5-mm or measured size die. Fix it in fix spindle and center the die pot.
 - ⊕ Count the number of squares occupied by the shadow of this pre measured die pot.
 - ⊕ Calculate the magnification of the shadow. For example, if a 5 mm die pot occupies 46 small squares (1 mm each) the magnification of the graph will be $46/5$. i.e. 9.2 X. This magnification quotient will be used later to set the Bruting radii.

OPERATING CONTROLS

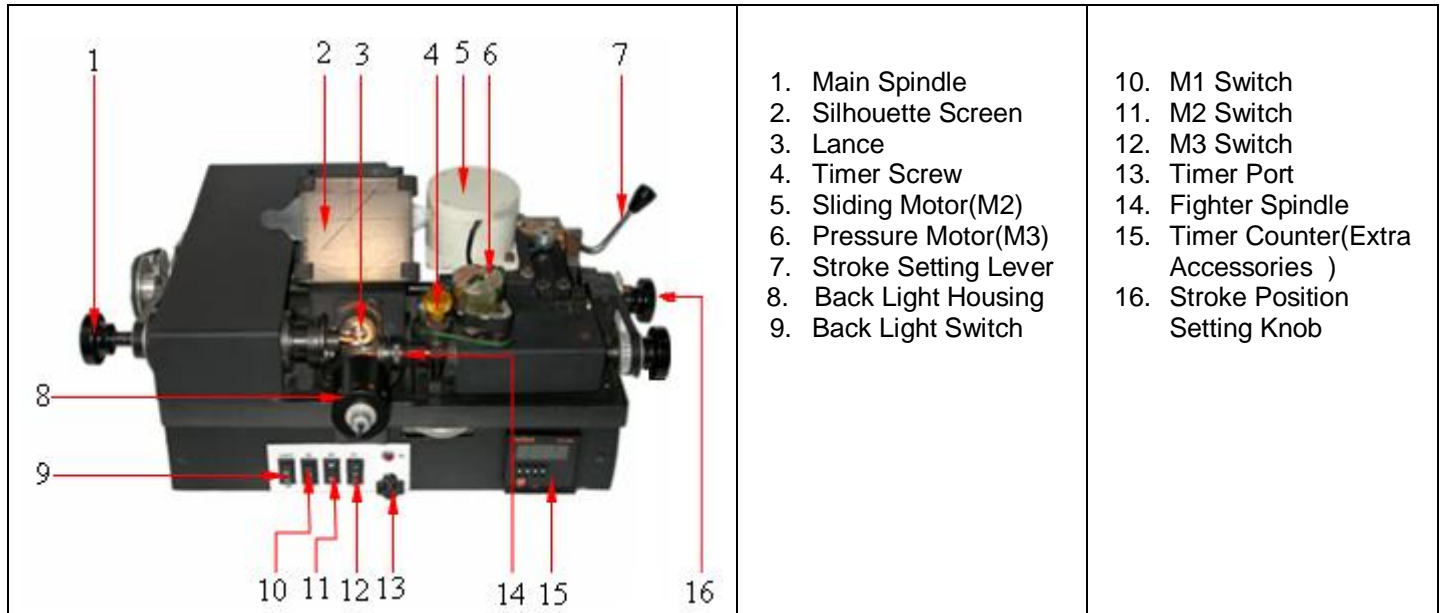

OPERATING INSTRUCTION

1. Keep the machine on a level surface with rigid structure.
2. Connect the power supply to the machine.
3. Glue the tentative table surface of the stone on the die pot. Take the glue as little as possible, just to remain between the table surface and the die pot-gluing surface. EXTRA GLUE DOES NOT ADD TO THE BONDING STRENGTH. *Gluing Station can be used to assist proper gluing process. Cure the glue by putting the die pot along with oven plate in oven for around 12 to 15 minutes at a temperature of 180 degree centigrade. LEVELLING OF OVEN IS VERY IMPORTANT TO AVOID SHIFTING OF THE STONE DURING GLUE CURING.
4. Keeping the machine Main Switch in OFF position, fix the fighter stone in the fighter spindle. Use 3 mm LN Key to tighten the grub screw on the die pot. Use of flat rejections or Poly Crystalline Diamond (PCD) as fighter will be beneficial.
5. Switch ON the light, and set the fighter using the projection details on the silhouette screen. Use the hammer to do so.
6. Take the fighter spindle down enough to avoid accident with the main stone.
7. If Fancy centering Machine is used for Planning and centering, fix the die pot with glued diamond in the centering chuck. This chuck is then fixed on to the centering machine. Based on the information from the centering machine, the stone has to be set to generate required size and shape. This centered chuck is then transferred to the Bruting machine, where multiplying the "Bruting radius value" with the "graph magnification factor" sets the Bruting line.



Centering Chuck

8. If Fancy Centering machine is not available, study the diamond, which is to be Bruted to fancy shape. Mark the corners, where the points will be required on the finished diamond. Plan the width and length of this stone. Calculate the Bruting radius required to process this stone based on the chart appearing below. Fix this stone die pot in the main spindle chuck using 3 mm LN Key to tighten the grub screw. Multiply the Bruting radius thus calculated, by the magnification of the graph. Say for example, if the Bruting radius comes to be 4.5mm, the Bruting line on the silhouette screen has to be set at 4.5 X magnification ratio of graph (say 9.2). i.e. 41.4 square above the centerline. Center the stone to brute on this Bruting radius. While centering the stone on the chuck, the screws can be loosened using 5mm LN Key. Lock the screws after centering.

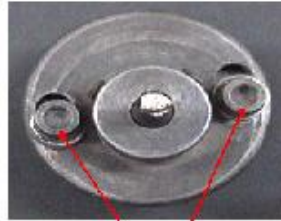

Screw which can be used to loosen the chuck - 5 mm

9. Bring the two stones closer to each other axially, while rotating the right back knob in anti-clockwise direction. Switch on the Main Switch and start spindle rotation by putting the M1 in forward rotation position. Cautiously bring the stones close together. Start M2 motor, and adjust the stroke size and position by respective lever / knob. Start the pressure by putting M3 motor switch in UP position. Set the timer knob for appropriate rate of cutting.
10. Keep a watch on the graph to terminate the Bruting process. Occasionally, the machine can be stopped (by switching OFF the main switch) to have a look at the stone more closely.
11. On approaching the required size, slow down the feed rate gradually (to zero) to get beardless surface of finish.

CHART FOR CALCULATING BRUTING RADIUS

L=Length of finished diamond.
D=Diameter of finished diamond

Timer **Timer Knob**

DISTANCE FROM CENTRE LINE FOR OVAL

L/D Ratio	Distance from center line	
	Distance from width side	Distance from Head side
1.22	0.75 X Diameter	0.40 X Diameter
1.25	0.77 X Diameter	"
1.28	0.80 X Diameter	"
1.30	0.82 X Diameter	"
1.32	0.83 X Diameter	"
1.35	0.86 X Diameter	"
1.40	0.91 X Diameter	"
1.42	0.93 X Diameter	"
1.45	0.96 X Diameter	"
1.50	0.99 X Diameter	"
1.55	1.05 X Diameter	0.404 X Diameter
1.58	1.09 X Diameter	"
1.60	1.11 X Diameter	"

DISTANCE FROM CENTRE LINE FOR MARQUISE

<u>L/D</u>	<u>Distance from centre line</u>	<u>L/D</u>	<u>Distance from centre line</u>
2.3	1.57 × Diameter	1.92	1.17 × Diameter
2.28	1.55 × Diameter	1.9	1.15 × Diameter
2.26	1.53 × Diameter	1.87	1.13 × Diameter
2.24	1.51 × Diameter	1.85	1.11 × Diameter
2.22	1.48 × Diameter	1.82	1.10 × Diameter
2.2	1.46 × Diameter	1.8	1.06 × Diameter
2.18	1.44 × Diameter	1.77	1.04 × Diameter
2.16	1.42 × Diameter	1.75	1.02 × Diameter
2.14	1.40 × Diameter	1.72	0.99 × Diameter
2.12	1.38 × Diameter	1.7	0.97 × Diameter
2.1	1.35 × Diameter	1.67	0.95 × Diameter
2.08	1.33 × Diameter	1.65	0.93 × Diameter
2.06	1.31 × Diameter	1.62	0.91 × Diameter
2.04	1.29 × Diameter	1.6	0.89 × Diameter
2.02	1.27 × Diameter	1.58	0.88 × Diameter
2	1.25 × Diameter	1.56	0.86 × Diameter
1.97	1.22 × Diameter	1.54	0.85 × Diameter
1.95	1.20 × Diameter	1.52	0.83 × Diameter

Example: If $L=7.2$ and $D=3.6$ then
 $L/D=2$ so Distance= $1.25 \times \text{Diameter} = 1.25 \times 3.6 = 4.50$

DISTANCE FROM CENTRE LINE FOR PEAR

L/D	Distance from width side	L/D	Distance from width side
1.32	0.93 X Diameter	1.52	1.29 X Diameter
35	0.96 X Diameter	1.55	1.35 X Diameter
1.38	1.02 X Diameter	1.58	1.41 X Diameter
40	1.06 X Diameter	1.60	1.46 X Diameter
1.42	1.09 X Diameter	1.62	1.51 X Diameter
1.45	1.17 X Diameter	1.65	1.56 X Diameter
1.48	1.21 X Diameter	1.68	1.65 X Diameter
1.50	1.24 X Diameter	1.50	1.24 X Diameter

TROUBLESHOOTING

Sr. No.	Problems	Reasons	Solutions
1	Pressure is not coming.	<ul style="list-style-type: none"> a. Timer switch is not ON. b. Timer screw is tight / jam. c. Timer switch is faulty. d. Timer motor's capacitor faulty. e. Threads of timer screw and nut are worn out. f. Belt is slipping. 	<ul style="list-style-type: none"> a. Switch ON the timer switch. b. Clean the timer screw using clean cloth. c. Change the timer switch. d. Change the capacitor. e. Change screw-nut set. f. Clean the belt using clean cloth or change the belt.
2	Machine is running slowly.	<ul style="list-style-type: none"> a. Rider knob is at slow position. b. Main motor belt is slipping. c. PTFE bush of the counter shaft may be dry. 	<ul style="list-style-type: none"> a. Turn the rider knob. b. Clean the motor belt using clean cloth or change the belt c. Put a few oil drops.
3	The main motor (M1) speed is not controlled by the rider.	<ul style="list-style-type: none"> a. Rider is faulty. 	<ul style="list-style-type: none"> a. Change the rider.

4	Sliding movement problem.	<ul style="list-style-type: none"> a. Sliding eccentric shaft may be tight between Nylon bush. b. There is an access clearance between eccentric shaft and the Nylons bush. c. Belt slipping d. Sliding motor (M2) is not running properly. 	<ul style="list-style-type: none"> a. Rotate the Nylon bush and create a little clearance. b. Rotate the Nylon bush and reduce the clearance. c. Clean the belt using neat cloth or change the belt. d. Change the capacitor of R-C circuit or change the M2-Motor.
5	Noise problem when machine is running at high speed.	<ul style="list-style-type: none"> a. Pedestal bearings of countershaft are dry. 	<ul style="list-style-type: none"> a. Put a few oil drops in the pedestal.
6	Noise from the fighter spindle.	<ul style="list-style-type: none"> a. Fighter spindle is in too much down position. b. Counter shaft PTFE bush may have worn out. c. Timing belt may have worn out. d. Timing pulley has worn out. 	<ul style="list-style-type: none"> a. Take fighter spindle in up position. b. Change countershaft bush. c. Change timing belt. d. Change timing pulley
7	Electric shock from machine.	<ul style="list-style-type: none"> a. Earthing is not proper. 	<ul style="list-style-type: none"> a. Make proper earthing in your factory wiring.

8	Noise problem in machine.	<ul style="list-style-type: none"> a. Main motor (M1) bearing may be faulty. (Can be confirmed by removing M1 motor belt). b. Counter shaft may be dry. c. Main (fixed) spindle bearing dry or worn out. d. Fighter spindle bearing dry or worn out. 	<ul style="list-style-type: none"> a. Change M1 motor bearing. b. Put oil drops in counter shaft pedestal. c. If dry then grease it and if worn out, change it. d. If dry then grease it and if worn out, change it.
9	Roundness of Diamond after zoeting is not good enough. (I.e. poorer than 99%)	<ul style="list-style-type: none"> a. Roundness is not achieved on whole diamond. (Uniform 'zoeting' is not found on the total girdle periphery.) b. Water is applied during zoeting cycle. c. Powder is removed from diamond before full roundness is achieved. d. Sliding-bearing pad has worn out. e. If uniform zoet is found on the total diamond periphery and roundness is not satisfactory, spindle bearings are not properly preloaded. 	<ul style="list-style-type: none"> a. Do not correct / tap the diamond just before zoeting cycle. b. Do not apply water. c. Do not remove powder during zoeting cycle. d. Change the sliding pad and bush. e. Check spindle Bearing and preload by tightening the locking nut.

10	Fuse blown again and again.	<ul style="list-style-type: none"> a. Wiring may be shorted. b. Main motor (M1) may be faulty. c. Transformer may be shorted. 	<ul style="list-style-type: none"> a. Check wiring. b. Check the main motor; if motor is shorted then change the motor. c. Change the transformer
11	Timer is moving fast.	<ul style="list-style-type: none"> a. In timer PCB circuit, the resistor value is 2kΩ. 	<ul style="list-style-type: none"> a. Replace 2kΩ resistor by 750Ω resistor.
12	Vibration found in machine.	<ul style="list-style-type: none"> a. Table is weak. 	<ul style="list-style-type: none"> a. Fix the table securely.